

03-71 series

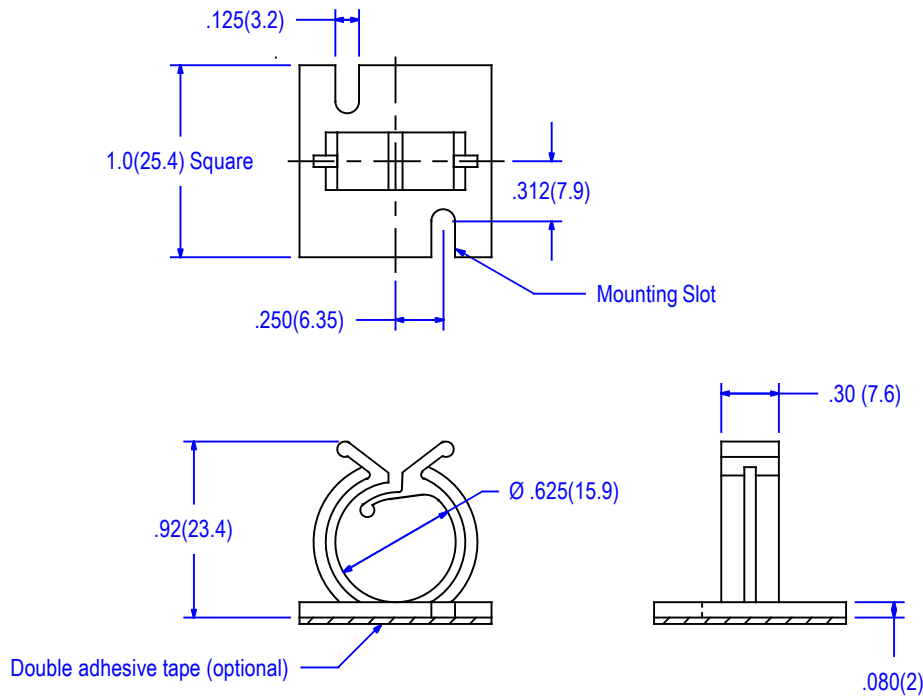

ITEM NUMBER	Mounting method
03-71-108	TAPE Double adhesive, 1/32 thick
03-71-10	No tape.Use screws (#4) or rivets

PACKAGING : 500 PER BAG

UL 94V-O MATERIAL AVAILABLE UPON REQUEST
TO ORDER ADD SUFFIX "X" TO ITEM NUMBER

ADHESIVE	ACRYLIC
CARRIER	POLYETHYLENE
THICKNESS	1/32
COLOR	WHITE
UL FILE NO.	NA
RoHS COMPLIANCE	YES
SERVICE TEMPERATURE	-4 to 248°F (-20 to 120 °C)
MR NUMBER	39

MATERIAL	NYLON 66
UL RATING	94V-2
UL FILE NO.	E41938
COLOR	NATURAL
ASTM	D 4066, PA111
RoHS COMPLIANCE	YES
TEMPERATURE RANGE (REF.)	-40 to 185°F (-40 to 85°C)
MR NUMBER	12

				BY	DATE	Title	
						WIRE ROUTER ON BASE.	
						03-71series.	
						Part No.	Issue
						See table	A
						DIMENSIONS Inches (mm) Tolerance .xx = ± .010 .xxx = .005	
.A	Added adhesive specs.MR-39	9-17-14	FL	ALL ELECTRONICS HARDWARE INC. 2642 Corporate Parkway Algonquin, IL. 60102 1-800-778-7234		Drwg. type	9-10-17
No	Revision	Date	Init.			CATALOG	
						File No.	03-71 series